

**FEATURES**

LO/RF Frequency:	3.5 – 7.0 GHz
Input IP3:	+23 dBm
Sideband Suppression:	-33 dBc
LO Leakage:	-35 dBm
LO Power:	+3 dBm
DC Power:	+5V @ 110 mA, -5V @ 40 mA

**DESCRIPTION**

The AM3570N quadrature modulator is ideal for converting baseband I/Q modulation directly to RF. I and Q baseband inputs linearly modulate the local oscillator (LO) signal to produce a modulated RF output.

The AM3570N includes an I/Q mixer, LO amplifier, I/Q lowpass filters, and I/Q differential amplifiers. Field-adjustable potentiometers allow the user to null the modulator's LO leakage. The AM3570N is available as a caseless PCB with SMA female connectors and a screw-terminal DC power connector.

The AM3570N can be interfaced directly with single-ended or differential I/Q sources including most high-speed DACs. For more information, please refer to the **MODULATOR INTERFACING** section of this datasheet.

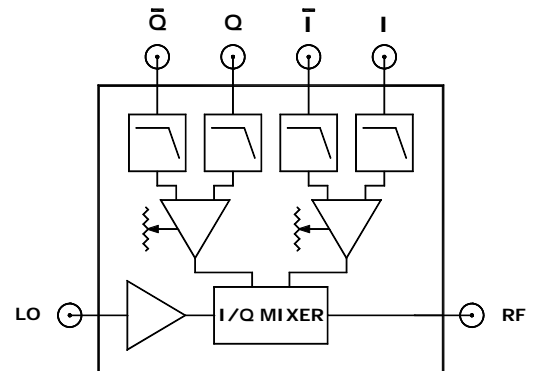

**TYPICAL APPLICATION: DIRECT CONVERSION TRANSMITTER**

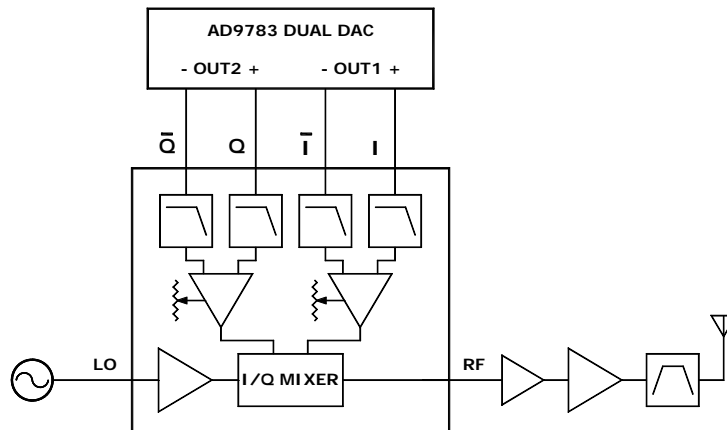

**ELECTRICAL SPECIFICATIONS**

Test Conditions: +25°C, LO = +3 dBm, I/Q inputs = 0 dBm total @ 100 kHz unless otherwise noted.

PARAMETER	TEST CONDITIONS	MIN	TYP	MAX	UNITS
LO/RF Frequency Range		3.5		7.0	GHz
+5V DC Supply Current			110		mA
-5V DC Supply Current			40		mA
LO Power		+1	+3	+5	dBm
LO VSWR			1.5:1		Ratio
RF VSWR			2.5:1		Ratio
I/Q Baseband Filter Bandwidth <sup>1</sup>	<3 dB Flatness	DC		300	MHz
I/Q Baseband Filter Stop Band <sup>1</sup>	>25 dB Rejection	450		5000	MHz
I/Q Input Differential Input Impedance			100		Ω
I/Q Input Common-Mode Range	100 Ω Diff. Source	-2.5		+2.5	V
I/Q Input Differential-Mode Range	100 Ω Diff. Source	-1		+1	V
Conversion Loss			6.5	9.0	dB
Input IP3	2-Tone, Δf = 1 MHz		+23		dBm
Output P1dB			+6		dBm
LO Leakage at RF Port	No RF input drive		-35	-20	dBm
Sideband Suppression <sup>2</sup>			-33	-25	dBc
Amplitude Imbalance		-0.4	±0.1	+0.4	dB
Quadrature Phase Error		-5	-2	+1	Degree
Output Noise Level	10 MHz Offset		-162		dBm/Hz
Operating Temperature Range		0		+50	°C
LO/RF/IQ Input Power w/o Damage				+16	dBm

Notes:

1. Standard lowpass filters. Contact factory for other options.
2. For upper sideband operation:  $I = \cos(t)$ ,  $\bar{I} = -\cos(t)$ ,  $Q = \sin(t)$ ,  $\bar{Q} = -\sin(t)$

**DIMENSION DRAWING**

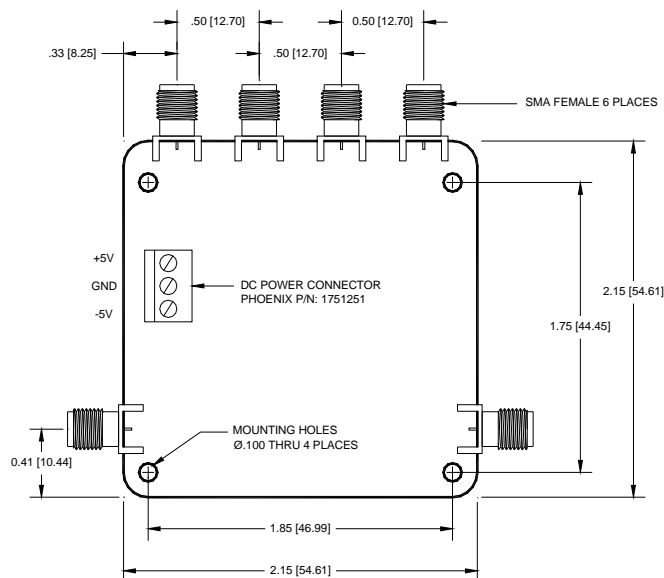

**TYPICAL PERFORMANCE CHARACTERISTICS**

Standard Test Conditions: +25°C, LO = +3 dBm, I/Q inputs = 0 dBm total @ 100 kHz.

**Conversion Loss**

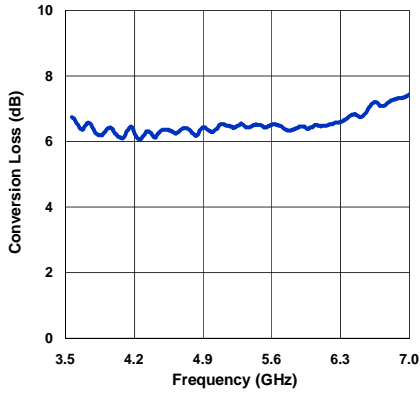

**Input IP3**

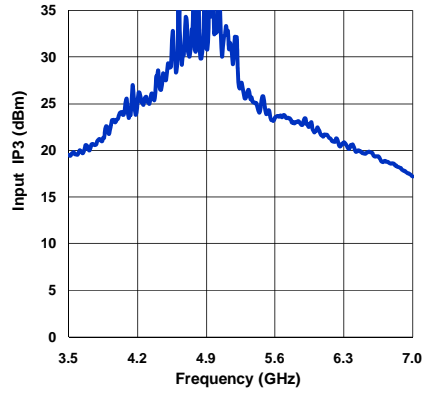

**LO Leakage at RF Port**

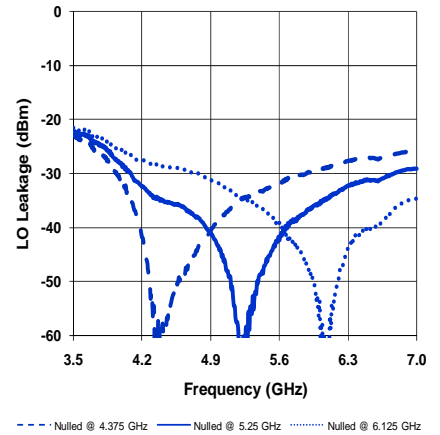

**Amplitude Imbalance**

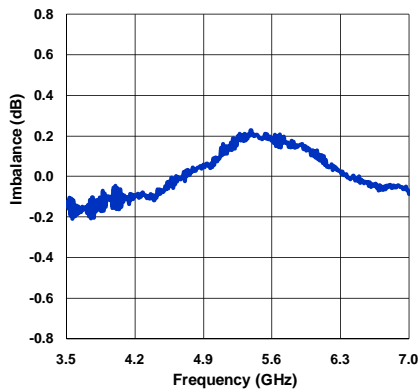

**Quadrature Phase Error**

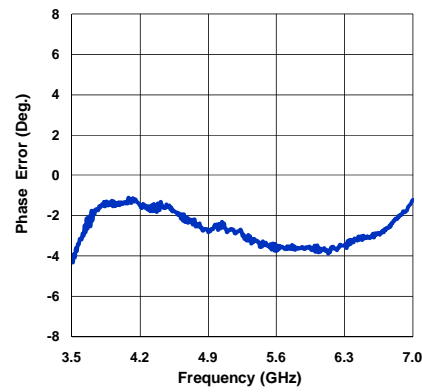

**Sideband Suppression**

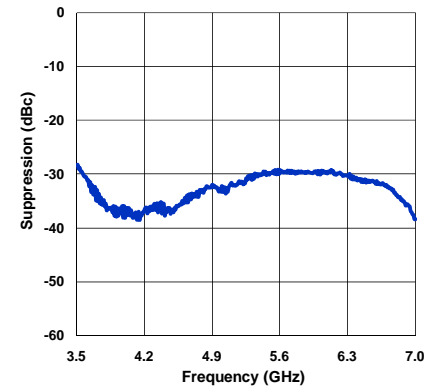

**I/Q Baseband Response**

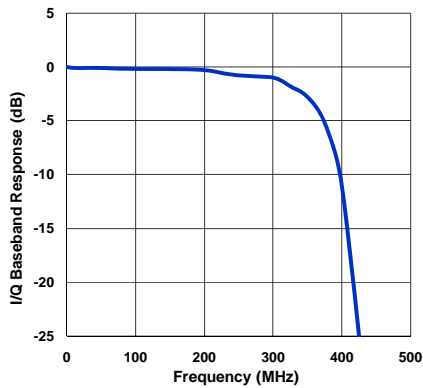

**Output P1dB**

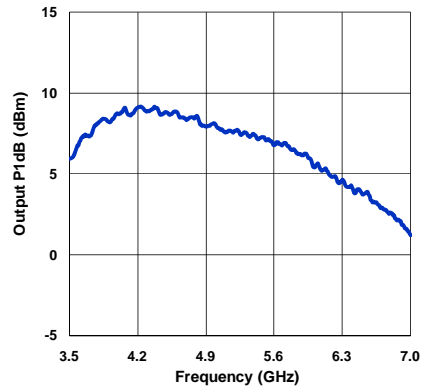

## MODULATOR INTERFACING

### I/Q INPUTS

The AM3570N is designed for easy interfacing to both single-ended and differential I and Q sources. The modulator's I and Q inputs are differential with 100 Ω input impedance. The I/Q common-mode voltage range (DC bias) is -2.5 V to +2.5 V. The differential-mode voltage range is -1 V to +1 V. Internal lowpass filters set the modulator's I/Q baseband 3 dB bandwidth to 300 MHz. Contact the factory for other available filter bandwidths.

### SINGLE-ENDED I/Q DRIVE

The AM3570N can be driven with single-ended I/Q signals having 50 Ω source impedance. Connect the single-ended I and Q signals directly to the modulator's I and Q inputs as shown in Figure 1. Leave the unused  $\bar{I}$  and  $\bar{Q}$  inputs open (do not terminate) for optimum LO leakage performance.

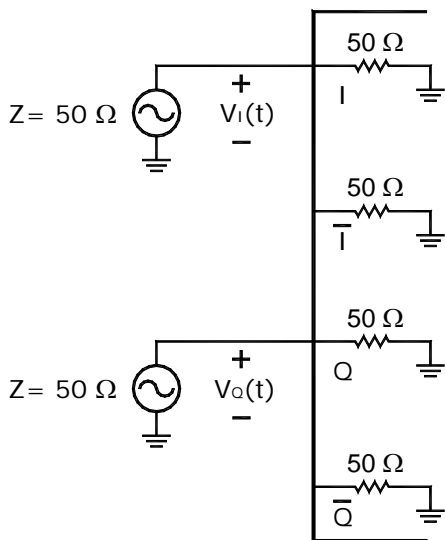

Figure 1. Single-Ended I/Q Drive

Any DC offsets present on single-ended input signals will result in increased LO leakage. Single-ended I and Q signals should be maintained within the voltage range of -2.5 V to +2.5 V.

### DAC INTERFACING

The AM3570N is designed for direct connection to high-speed DACs having differential current-source outputs. One example is the Analog Devices AD9783, a dual 16-bit 500 MSPS DAC. Figure 2 shows the AD9783 DAC driving the AM3570N modulator. No external resistors, amplifiers, or filters are required.

When configured for 20 mA full-scale current, the AD9783 provides the AM3570N with 1 V<sub>p-p</sub> differential signals centered at a common-mode voltage of 500 mV.

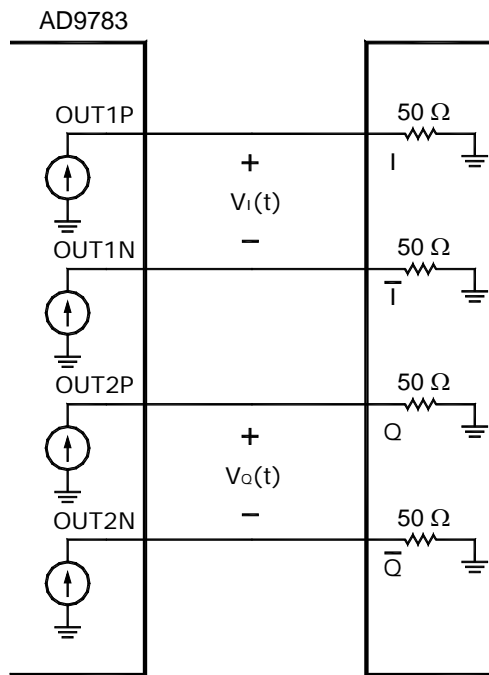

Figure 2. AD9783 Driving AM3570N