

Driving the QM Series Quadrature Modulators

by Lowell Hoover

INTRODUCTION

The QM series quadrature modulators provide exceptional linearity for demanding direct conversion transmitter designs. This note outlines common methods of interfacing the QM series modulators to single-ended and differential I/Q sources including modern Digital-to-Analog (D/A) converters.

MODULATOR OVERVIEW

The block diagram of a QM series modulator is shown in Figure 1. For correct operation, the modulator should be supplied with an LO drive signal having a power level within the modulator's specified LO power range. The LO signal should have better than -30 dBc 2nd harmonic content to achieve the rated LO leakage performance. The modulator's LO and RF ports are single-ended and matched to 50 Ω .

The two differential baseband inputs, I/\bar{I} and Q/\bar{Q} , each have 100 Ω differential input impedance. Internally matched lowpass filters on the baseband inputs limit the modulator's baseband bandwidth.

DRIVING THE I/Q BASEBAND INPUTS

To minimize distortion and LO leakage, differential signals should be used to drive the modulator's I/Q baseband inputs. The two baseband input pairs, I/\bar{I} and Q/\bar{Q} , should be driven differentially with signal sources having 100 Ω source impedance (see Figure 2). The common-mode voltage should be 0 V (ground) to achieve the modulator's specified LO leakage.

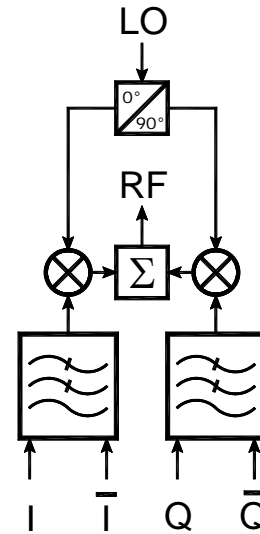

Figure 1. Modulator Block Diagram

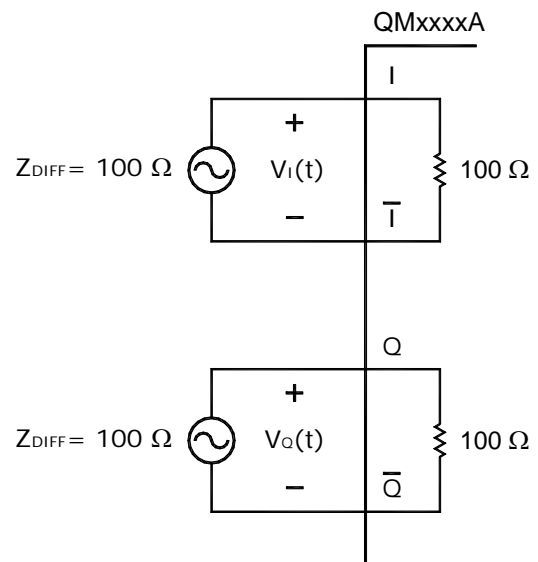

Figure 2. I/Q Ports Equivalent Circuit (Differential)

Differential drive can also be accomplished using 4 single-ended sources each with 50 Ω source impedance. Figure 3 is the single-ended equivalent circuit.

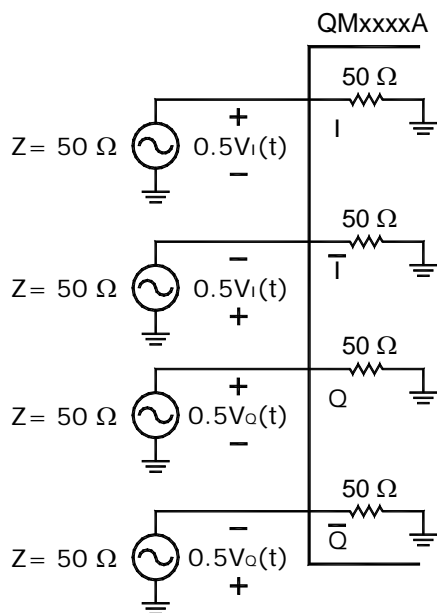

Figure 3. 4 Single-Ended Sources Driving the I/Q Ports

To drive the modulator with an upper-sideband tone, the I/Q baseband input voltages should be

$$V_I(t) = A \cos(2\pi f_m t)$$

$$V_Q(t) = A \sin(2\pi f_m t)$$

where A is the amplitude in Volts and f_m is the frequency in Hertz. The total I/Q input power delivered to the modulator is related to the amplitude of the I/Q drive signals by:

$$\text{Input Power (dBm)} = 20 \log_{10}(A) + 10$$

For example, the amplitude A of the input sinusoids should be 316 mV to give +0 dBm I/Q drive.

INTERFACING TO SINGLE-ENDED I/Q SOURCES

When only single-ended I and Q signals are available, a means of converting to differential signals is required. A simple differential amplifier

circuit based on the Analog Devices¹ AD8132 is shown in Figure 4. This circuit provides excellent amplitude and phase tracking from DC to 200 MHz. The V_{ocm} inputs should be connected to ground to minimize LO leakage.

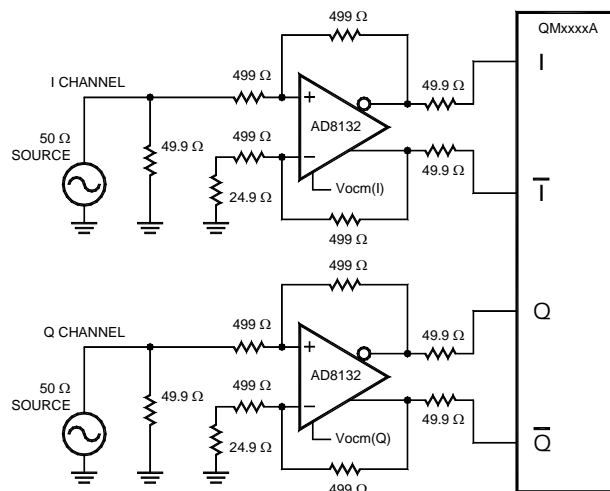

Figure 4. Interface to Single-Ended I/Q Sources

The transformer circuit shown in Figure 5 provides an all-passive method of converting single-ended I and Q sources to differential drive. The transformer is AC-coupled and cannot be used in applications that require DC response. This transformer interface has excellent amplitude and phase response from 100 kHz to over 300 MHz.

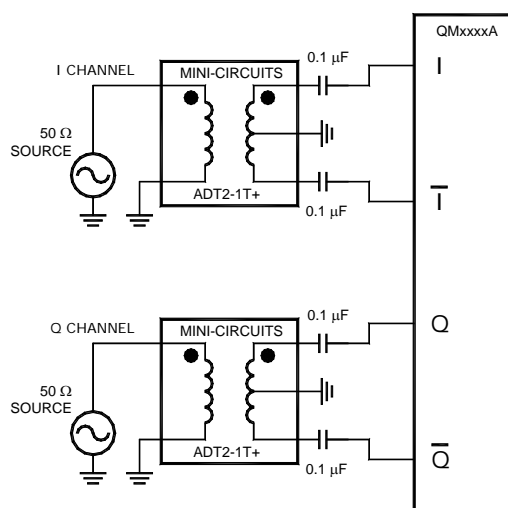

Figure 5. Transformer Interface

D/A CONVERTER INTERFACING

Most high speed (>100 MS/s) D/A converters use switched-current differential outputs. The Analog Devices AD9783² has dual differential outputs that source current into ground-referenced load resistors. The AD9783 is easily interfaced to the QM series modulators with the circuit shown in Figure 6. When the AD9783 is set for 20 mA maximum output current it will have a common-mode output voltage of 500 mV and a 1 V differential voltage range. The AD8132 differential amplifier circuit moves the common-mode voltage to 0 V (ground) and provides the modulator with the correct source impedance.

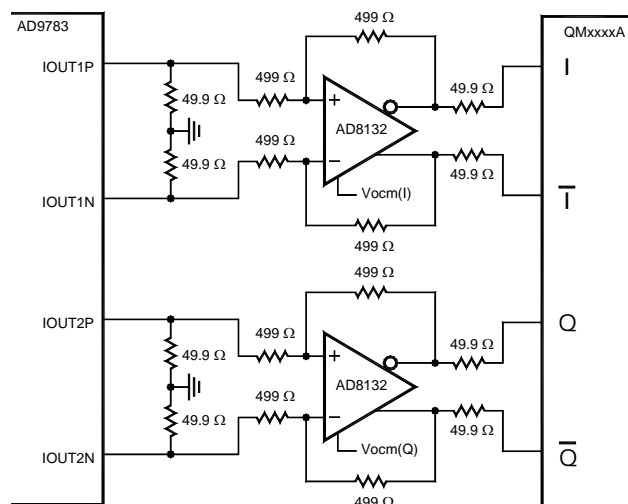

Figure 6. Interface to AD9783 Dual D/A Converter

The V_{ocm} inputs should be connected to ground to minimize LO leakage.

By adding capacitors to the feedback paths of the circuit shown in Figure 6, an active low-pass filter function can be added to set the noise bandwidth of the D/A converter's output signals.

REFERENCES

- [1] Analog Devices, Inc., "AD8132 Product Datasheet, Rev. F", 2006.
- [2] Analog Devices, Inc., "AD9783 Product Datasheet, Rev. A", 2008.